

# Product Manual

## 232-STSi

---

Stereo PAL TV Tuner, S-Video

Version 6.3 January 26, 2010



4355 Excel Pkwy, Suite 600, Addison, TX, 75001  
Phone: 972-931-2728 • Toll-Free: 888-972-2728 • Fax: 972-931-2765  
E-Mail: [Sales@crwww.com](mailto:Sales@crwww.com) • Website: [www.crwww.com](http://www.crwww.com)

# Table of Contents

<b>Overview</b> .....	<b>3</b>
<b>Specifications</b> .....	<b>4</b>
Physical .....	4
RF Tuner .....	4
IC-RC Remote Control (Optional) .....	4
Front Panel .....	4
Rear Panel .....	5
Internal Character Generator/Captioning .....	5
Includes .....	5
Options .....	5
<b>Front Panel Programming</b> .....	<b>6</b>
Modes 10 and above .....	6
<b>Front Panel Programming Commands</b> .....	<b>7</b>
<b>Channel Tuning and Presets</b> .....	<b>8</b>
<b>RS-232 Control Protocol</b> .....	<b>9</b>
Overview .....	9
General protocol specifications .....	9
Command String Structure .....	9
General RS-232 Commands .....	10
Character Generator Commands .....	13
Keypad Channel Command .....	14
IC-RC Remote Emulation .....	14
Preset Commands and Replies .....	15
Terminal Communication Commands .....	15
RS-232 Command Hints and Tips .....	15
<b>Response Strings</b> .....	<b>16</b>
Channel/Source Status Response String (T): .....	16
Audio Status Response String (V): .....	16
Front Panel Mode Status Response String (S): .....	16
Q Mode Response String (Q): .....	16
<b>RS-232 Cable Connections</b> .....	<b>17</b>
Single Tuner .....	17
Multiple Tuners .....	17
<b>Rack Mounting</b> .....	<b>18</b>
RK1 Single Unit Rack Mount .....	18
RK2 Side-by-Side Rack Kit .....	18
<b>Safety Instructions</b> .....	<b>19</b>
<b>Limited Warranty and Disclaimer</b> .....	<b>20</b>

## Overview



The Contemporary Research 232-STSi Stereo S-Video PAL Tuner is a versatile RS-232 controlled PAL TV tuner featuring high-quality S-Video video and balanced A2/NICAM stereo audio output, switchable composite AV input, closed-captioning and on-screen text, 125 Channel Preset memory, front-panel operation and feedback, and intelligent RS-232 control. Designed for global applications, the 232-STSi is CE listed and receives PAL B/G/ H, D/K, and I standards, as well as SECAM B/G, D/K, and L.

The 232-STSi features a new, versatile solution for auto-tuning broadcasts that allows the user to mix and match different TV standards. For example, a viewer in Germany (PAL B/G, A2 audio) can also save presets for Belgian broadcasts (PAL B/G, NICAM audio). Channel preset search, TV standard, add, and delete can be controlled from optional iC-RC remote or control system programming.

An onboard character generator displays on-screen text for closed captioning, channel names, interactive menus, and system feedback. Switchable inputs for composite video and stereo audio are included for display of PC graphics, VCR, camera or other A/V sources. AV from inputs and off-air broadcast are output as composite video, S-Video and Stereo, Mono, or Dual audio.

- Tunes PAL CATV and off-air frequencies, storing up to 125 Channel Presets in memory, firmware version 6.2 adds SECAM L tuning.
- Operates with free Tuner Helper software, available from [www.crwww.com](http://www.crwww.com)
- Features intelligent auto-tuning of TV frequencies, with the ability to save channel presets that include the frequency and TV Standard
- Outputs S-Video signal for improved image quality for monitors, large-screen displays and video projectors, employing adaptive comb and anti-aliasing filtering, as well as cross-color and cross-luminance reduction
- Delivers balanced A2/NICAM Stereo audio with programmable volume, as well as Mono and Dual A/B audio
- Switches between tuner and composite stereo AV inputs, output as composite and S-Video NTSC video
- Operates using one of several control pathways:
  - Full bi-directional RS-232 control and status feedback, AMX and Crestron modules available
  - Control up to 9 232-Series tuners from a single RS-232 control port
  - PC control using free .NET Tuner Helper software (great for saving tuner channels and setup information)
  - Front-panel programming options for tuning, RS-232 and operation setup
  - Optional IC-RC IR wireless remote, discrete IR and wired IR codes
  - Contact closure channel up/down
- Displays Line 22 closed-captioning and on-screen text channel names, interactive menus, and system feedback
- Restores all operation status after loss of power from data stored in non-volatile memory
- Inserts blue screen video image when unit senses loss of video level
- Mounts in 19" rack with optional RK1 or RK2 kit for dual side-by-side installation
- Upgradeable firmware via S12 Flash program, downloadable from [www.crwww.com](http://www.crwww.com)
- Includes IR In jack for external sensor or wired IR

## Specifications

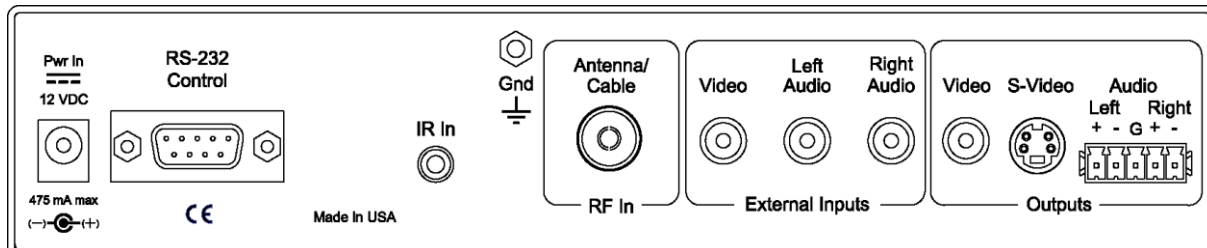
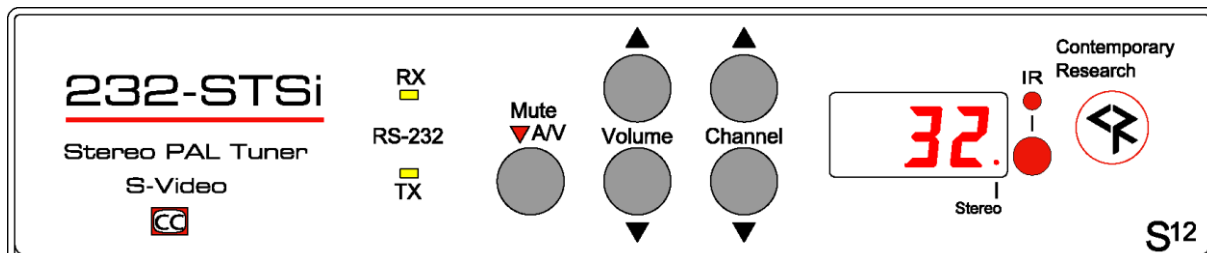

### Physical

Size:	8.5" [216mm] wide x 1.75" [38mm] height (1RU) x 6.0" [153mm] deep
Weight:	1.5 lbs [0.68kg]
Enclosure:	All aluminum with durable black powder coat paint
Mounting:	Rack mounting for one or two units side-by-side optional (RK1, RK2)

### RF Tuner

Channels:	Up to 125 Channel Presets in non-volatile memory
Frequency:	48 to 863 MHz, 50 KHz fine tune resolution
PAL:	PAL B/G/H A2 and NICAM, D/K A2 and NICAM, I NICAM
SECAM:	SECAM B/G A2, D/K, A2 and NICAM audio
SECAM L:	No closed captioning, on-screen text or blue screen, or S-Video
Maximum Input:	+20dBmV max, +10dBmV nominal
Video Gain:	±5% maximum, 2% typical
Video Phase:	±3 degrees maximum, 2 degrees typical

### IC-RC Remote Control (Optional)

Keypad:	Channel selection, press Enter to select channel
Volume:	Up, Down and Mute
Channel:	Channel Up, Down
Presets:	Up, Down, Left, Right, and Top keys search, add, and delete channel presets
CC:	Selects Closed Captioning
Input:	Toggles between External AV input and tuner channel

### Front Panel

RS-232 LEDs:	Yellow LEDs light when RS-232 data is transmitted (TX) or received (RX)
Mute A/V:	Mutes audio and video (blanks video)
Mute LED:	Red LED lights when A/V is muted
Volume:	Up and down buttons raises and lowers volume or selects programming mode
Channel:	Up and down buttons select channel presets 1-125, 126 selects external AV inputs
IR LED:	Red LED lights when receiving IR data, internal IR sensor below or from external receiver (optional)
Display:	Red LED 3 digit, 7 segment LED display for channels and modes Stereo LED indicates Stereo and Dual modes

## Specifications

### Rear Panel

Power In:	2.1mm coaxial jack (inside center conductor positive), 475 mA maximum 10.5 to 14.5 VDC, 12 VDC typical (may be unregulated)
RS-232 Control:	DB-9 male connector User selectable 300 to 19,200 (9600 default) baud, 8 data bits, no parity, 1 stop bit Employs standard ASCII strings from any terminal program, PC, or control system Can accept non-standard RS-232, including 0 to +5 VDC operation
Closures:	2 momentary closure inputs - Channel Up (Pin 4), Down (Pin 9), GND (Pin 5)
IR In:	3.5mm stereo jack for optional IR-RXC IR Receiver Sleeve= DC power+ from power jack input, limited to less than 100mA Ring=DC power- (GND) Tip= IR data signal
GND:	Grounding lug
Antenna/Cable:	IEC, female, 75 ohm impedance
Video Input:	RCA female, NTSC composite
Audio Inputs:	2 RCA female stereo unbalanced, 20K ohms impedance Maximum level +8dBu, (2V RMS), Reference: 0 dBu = .775 V RMS
Video Output:	RCA composite output, 1V p-p at 75 ohm impedance,
S-Video Output:	Mini DIN 4-pin, Y - 1V p-p at 75 ohms, C - 0.286 V p-p at 75 ohms (PAL only)
Audio Outputs:	5-Pin captive screw terminal, stereo, 200 ohm balanced/100 ohm unbalanced Selectable for stereo, mono and dual modes
Stereo/Dual:	Total Harmonic Distortion (THD): 0.6% maximum, 0.3% typical Response: 30Hz to 14KHz, Channel Separation: 40dB minimum, 45dB typical
Mono:	Total Harmonic Distortion (THD) 0.6%, 0.2% typical Response: 20Hz to 20KHz
Level:	+4 dBu (1.2V RMS) balanced, 0 dBu (.8V RMS) unbalanced, typical at max volume +11.5 dBu (2.9V RMS) balanced, +8 dBu (2V RMS) unbalanced peak max output
Volume:	0 to -62 dB and mute in 64 steps

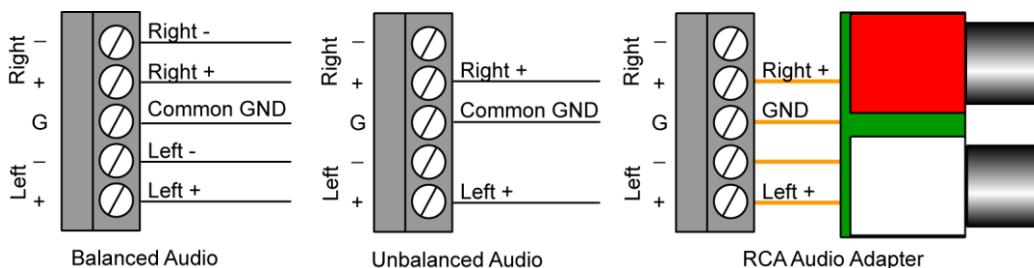

### Internal Character Generator/Captioning

Characters:	ASCII with international symbols
Format:	White text over video or white text with black background over video, Up to 32 characters, 13 lines
Function:	Closed captioning, channel labels, interactive menus, messages, and system feedback
Captioning:	Line 22 modes CC1-CC4, TT1-TT4, On/On with Mute/Off modes, CG text times out to show captioning
Muting:	Displays blue video image when loss of video is sensed

### Includes

12 VDC power supply, 850 mA, 110/220 VAC, includes adapters for Euro, UK, Australian and US-style plugs  
Plug-in adapter for unbalanced stereo RCA wiring

### Options

CC-232 RS-232 Cable  
IC-RC Wireless IR Remote, IR-RXC External IR Receiver also available, accepts Xantech® and other IR sensors  
RK1 Kit for mounting single unit in 19" rack, RK2 Kit for mounting two units side-by-side in 19" rack

## Front Panel Programming

**To Enter** a Front Panel Programming Mode:

1. Press **and hold** the Mute A/V button such that the red LED light above is lit (indicating Mute On).
2. Press Volume Up.
3. Release all buttons, the 232-STSi will now be in the front panel programming mode.
4. The front panel display is dedicated to programming information display while in this mode.
5. Changes are saved in non-volatile memory as they are entered.
6. The Volume up/down buttons scroll through programming modes 0 through 9 and 10+.
7. The Channel up/down buttons scroll through possible parameters for each mode.

**To Exit** the Front Panel Mode

Push and release the Mute All A/V button.

### Modes 10 and above

When you select programming mode 10 and above, the Mode digit and decimal point will flash. For example, if Mode 14 is selected, the display will show a flashing **4.** - followed by the current parameter setting.

The Modes 10 – 14 are identical to RS-232 Commands Q0 – Q4.

## Front Panel Programming Commands

Mode	0-9	Parameters	Mode	10+	Parameters
Channel Plans	<b>0.0</b>	Not applicable	Caption Type	<b>10.0</b> <b>10.1</b> <b>10.2</b>	Captioning off (default) Captioning on Captioning on with mute
Baud Rate	<b>1.1</b> <b>1.2</b> <b>1.3</b> <b>1.4</b> <b>1.5</b> <b>1.6</b> <b>1.7</b>	300 600 1200 2400 4800 9600 19200	Caption Mode	<b>11.1</b> <b>11.2</b> <b>11.3</b> <b>11.4</b> <b>11.X</b>	1=Caption 1 (default) 2=Caption 2 3=Caption 3 4=Caption 4 5 - 8= Text 1-4 (rarely used)
Unit Number	<b>2.1</b> <b>2.2</b> <b>2.3</b> <b>2.x</b>	One Two Three Four – Nine	Video Detect	<b>12.0</b> <b>12.2</b>	AV mutes when video lost* Only video mutes*
TV Standards	<b>3.1</b> <b>3.2</b> <b>3.3</b> <b>3.4</b> <b>3.5</b> <b>3.6</b> <b>3.7</b> <b>3.8</b>	PAL/SECAM B/G/H A2 (Rev 6.1) PAL/SECAM D/K A2 (Rev 6.3) PALSECAM B/G/H NICAM (Rev 6.1) PAL/SECAM D/K NICAM (Rev 6.1) PAL I NICAM (3.9) SECAM L (Rev 6.2) Future Future	AV Status	<b>13.0</b> <b>13.1</b> <b>13.2</b> <b>13.3</b>	No AV status (default) Stereo/Mono status only Video Loss status only Both status sent
Panel Lockout	<b>4.0</b> <b>4.1</b> <b>4.2</b> <b>4.3</b> <b>4.4</b> <b>4.5</b> <b>4.6</b> <b>4.7</b>	None Channel up/dwn Volume up/dwn Channel & Volume up/dwn Mute A/V Channel up/dwn & Mute A/V Volume up/dwn & Mute A/V All	Label Mode	<b>14.0</b> <b>14.1</b> <b>14.2</b> <b>14.3</b>	None Alpha only Numeric only Both
Power-up Volume	<b>5.0</b> <b>5.X</b>	restore previous level <b>1 – 63</b> sets volume level			
Firmware Version	<b>6.38</b>	Ex: Version 3.8 - Press and hold Channel Up, then Mute AV to restore tuner to default settings			
Audio Decode	<b>7.0</b> <b>7.1</b> <b>7.2</b> <b>7.3</b>	Mono - both A channels Stereo/Dual/Mono A auto-sense* Dual A and B/Mono A auto-sense Mono - both B channels *Auto-senses – if no stereo, switches to Dual, if no Dual, switches to Mono A			
Bass Gain	<b>8.8</b>	Fixed 0 dB bass level			
Treble Gain	<b>9.4</b>	Fixed 0 dB treble level			*Audio is always unmuted when external AV inputs are selected

## Channel Tuning and Presets

The new auto-scan capability of the 232-STSi allows the user to search for channel frequencies, select a TV standard, and save as a numbered channel Preset that includes the frequency and TV standard. Using this feature, channel Presets can include broadcasts from neighboring countries with different audio standards.

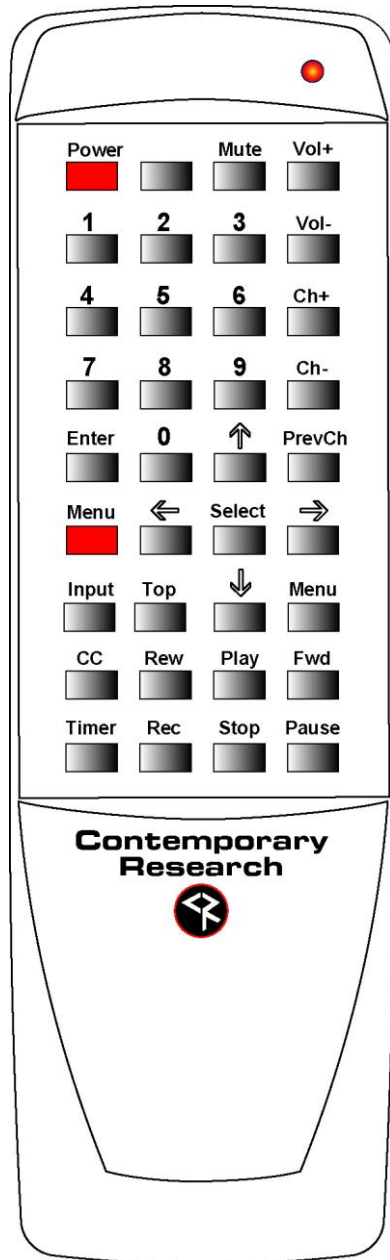

Scanning and adding channel presets can be performed via RS-232 commands, Tuner Helper software, and the optional IC-RC IR wireless remote. For simplicity, the following instructions are based on the IC-RC remote pictured on the left.

### Zeroing Out Presets

Press the "0" key, then the **Arrow Left** key (Delete Preset) to clear all Presets in memory.

### Set Starting Frequency

The 232-STSi will scan up or down starting from the current frequency in memory, and will stop when it finds a station with a valid video signal. Scanning stops when it hits the lowest or highest frequency, it does not cycle back to the beginning or end.

To start at the lowest frequency, unplug the RF feed then press the **Down Arrow** to Scan Down. Reconnect the RF feed for the next steps.

### Select TV Standard

Press the **Top** key to step through TV standards – the tuner will display on-screen text to confirm which standard is active. The first standard to appear is the current setting.

- PAL B/G/H A2
- PAL D/K NICAM
- PAL B/G/H NICAM
- PAL I NICAM

### Search for Broadcasts

Press the **Arrow Up** to search for the first broadcast frequency.

### Save Channel Preset

To save the current channel and TV Standard, enter a **Preset** number between 1 and 125, and then press the **Right Arrow** key to save.

To do a quick save, press **Right Arrow** without a number. The tuner will save as the last channel deleted or the next highest available channel.

Press Arrow Up or Arrow Down to search for the next frequency.

### Changing TV Standard

If the found channel has good video, but no or poor audio, it may be using a different TV Standard than your current setting. Press the **Top** button until the audio quality improves.

If you are changing the standard of an existing preset, it will display as "0" until you return to the current setting or save the preset.

### Delete Preset

Enter a channel preset number, and then press the **Left Arrow** key. If you delete a preset by mistake, press the **Right Arrow** key immediately to restore the preset. Enter a "0" and **Left Arrow** to clear all Channel presets.

### View Channel Presets

Press the **Channel+** and **Channel-** keys to view currently saved Channel Presets.



## Overview

The 232-STSi full duplex RS-232 scheme enables a system programmer to control all TV Tuner functions as well as monitor 3 groups of TV Tuner status. All commands are sent as ASCII strings. No delays between characters or commands are required, as data is interrupt driven and buffered.

The 3 status groups are: Channel/Source Select, Audio Levels/Mode and Front Panel. The Mute A/V button-function status from the 232-STSi front panel has been grouped with the Channel/Source for simplicity in the most common modes of operation. Each of the groups has one ASCII status response string containing all of the status data for that group. The current status string of a group is sent from the 232-STSi whenever a valid command for that group is received by the 232-STSi RS-232 port or front panel. A group's status may be requested at any time via the RS-232 port. Status of all 3 groups is sent at power up. The format of each group's status response string remains the same always.

Up to 9 232-STSi units may be cabled together and addressed for individual control from a single RS-232 port. Each 232-STSi is assigned a unique unit code (Front Panel Mode 2).

Communications parameters (Front Panel Mode 1) are 300 to 19.2K baud, 8 data bits, No parity, and 1 stop bit. Factory default is 9600 baud, Unit#1.

All settings are saved to NVRAM in the 232-STSi.

The tuner will accept non-standard RS-232 control such as voltage that swings from 0 to +5 VDC, commonly found when IR ports are used to send RS-232 commands.

## General protocol specifications

Characters in command strings to the 232-STSi are common ASCII keyboard characters.

Command strings sent to the 232-STSi begin with the ASCII > (greater than symbol) as an 'Attention' character and end with carriage return - ASCII CR, Hex \$0D, or keyboard Enter - as an 'End-of-command' character.

Responses from the 232-STSi begin with the ASCII < (less than symbol) as an 'Attention' character and end with a carriage return followed by line feed an ASCII LF or Hex \$0A as 'End-of-command' characters.

A carriage return is required at the end of each command and is assumed in all examples.

## Command String Structure

[Attention] (Unit#) [Command] (Parameters) [Return]

<b>Attention</b>	Single character (>) starts the string
<b>Unit#</b>	The Unit# is expressed as an ASCII 1 2 or 3 when used in multi 232-STSi applications. It may be omitted for a default of Unit#1 for a single 232-STSi set as Unit#1.
<b>Command</b>	A two-character command
<b>Parameters</b>	Added attributes to some commands
<b>Return</b>	A carriage return ends the command string, you may use ASCII CR, Hex \$0D, or keyboard 'Enter' in programming. For simplicity, the programming examples in the manual will not show the 'CR' – so remember, you'll need to add it in your control code.

## General Commands

<b>Q0=</b>	Caption Mode Off (0-2)  <i>Example: '&gt;Q0=0' or '&gt;Q00'</i>	Sets captioning mode 0=Captioning off (default) 1=Captioning on 2=Captioning active when volume is muted  <i>Captioning off</i>
<b>Q1=</b>	Captioning Type (1-8)	Turns on captioning type 1=Caption 1 (normal setting for most captioning) 2=Caption 2 3=Caption 3 4=Caption 4 5-8= Text 1-4 (rarely used)
<b>Q2=</b>	Video Loss Detection (0-3)	Selects response when a loss of video signal is detected 0=Both audio and video muted (default-blue screen for video) 2=Video muted, audio active  Audio is always unmuted when external AV inputs are selected
<b>Q3=</b>	AV Detect Status (0-3)	Enables/disables sending status response when Stereo/Mono or Video Loss Detect changes. Only status operation is affected, the functions continue to operate.  0=Disable Stereo/Mono and Video Loss Detect status (default) 1=Enable Stereo/Mono, disable Video Loss Detect 2=Enable Video Loss Detect, Disable Stereo/Mono 3=Enable Stereo/Mono and Video Loss Detect status
<b>Q4=</b>	Label Mode with Status (0-3)  <i>Example: '&gt;Q4=2'</i>	Sets on-screen channel label mode. Same as TM, current mode reflected in status, setting TM will also change Q4. (Ver 3.1)  0=None 1=Alpha only 2=Numeric only (default) 3=Both alpha and numeric labels  Channel labels are displayed overlaying the video in the top-left corner of the screen for about 10 seconds after each channel change. <i>Tuner displays the channel number only.</i>

## **RS-232 Control - General Commands**

<b>S0=</b>	Set Channel Plan	Not Applicable
<b>S3=</b>	TV Standard  <i>Example: `&gt;S3`</i>	1=PAL B/G/H A2 (Rev 6.1) 2=Future 3=PAL B/G/H NICAM (Rev 6.1) 4=PAL D/K NICAM (Rev 6.1) 5=PAL I NICAM (Rev 6.1) 6=SECAM L (Rev 6.2) 7=SECAM B/G/H (Future) 8=SECAM D/K (Future) Null=Toggling, as with Top IR or KK 104 <i>Steps through TV Standards</i>
<b>S4=</b>	Set front panel lockout mode	0=None 1=Channel 2=Volume 3=Channel & Volume 4=Mute A/V 5=Channel & Mute A/V 6=Volume & Mute A/V 7=All
<b>S5=</b>	Power-up volume	0=restore to previous level 1-63= Restore to preset volume level (1 min, 63 max)
<b>S7=</b>	Set audio mode	0=Mono - both A channels 1=Stereo/Dual/Mono A auto-sense (default) 2=Dual A and B/Mono A auto-sense 3=Mono - both B channels
<b>S8=</b>	Set bass gain level	Fixed at 0 dB
<b>S9=</b>	Set treble gain level	Fixed at 0 dB
<b>SQ</b>	Request Q Mode status	Unit sends "Q" Mode status string
<b>SS</b>	Request Front Panel status	Unit sends "S" Front Panel status string
<b>ST</b>	Request Channel status <i>Example: `&gt;ST`</i>	Unit sends "T" Channel/Source status string <i>Returns Channel/Source status response string</i>
<b>SV</b>	Request A/V status	Unit sends "V" Audio status string
<b>TR=</b>	Set Tune Ring (TR)	Not applicable
<b>TT=</b>	Select channel preset  <i>Example: `&gt;TT=28`</i>	0=video mute 255=mute off 126=External AV Input <i>Selects channel preset 28</i>
<b>TC=</b>	Select channel preset  <i>Example: `&gt;TC=39`</i>	0=video mute, 255=mute off, does not change audio level 126=External AV Input <i>Selects channel preset 39</i>
<b>TP</b>	Previous channel	Selects previous channel
<b>T]</b>	Search up	Searches for next higher frequency
<b>T[</b>	Search down	Searches for next lower frequency
<b>TS=</b>	Add Preset <i>Example: `&gt;TS=22`</i> <i>Example: `&gt;TS`</i>	Saves preset to memory, includes preset #, frequency, TV Standard <i>Saves data to Preset 22, replaces previous data at that address</i> <i>Acts like Right Arrow Key - adds preset</i>
<b>TE=</b>	Delete Preset <i>Example: `&gt;TE=24`</i> <i>Example: `&gt;TE=24-99`</i> <i>Example: `&gt;TE`</i>	Deletes one or more channel presets <i>Deletes Preset 24</i> <i>Deletes all channels between 24 and 99</i> <i>Acts like Left Arrow Key - deletes current preset</i>
<b>TU</b>	Tune preset up <i>Example: `&gt;3TU`</i>	Selects next higher channel preset <i>Bumps Unit#3 tuned channel up</i>
<b>TD</b>	Tune preset down	Selects next lower channel preset

## **RS-232 Control – General Commands**

<b>XX</b>	Mute A/V off	Turn A/V outputs on at previous level
<b>XM</b>	Mute A/V on <i>Example: '&gt;XM'</i>	Mutes A/V outputs <i>Mutes audio and video outputs</i>
<b>P0</b>	Power Off	Same as XM
<b>P1</b>	Power On	Same as XX
<b>PT</b>	Power Toggle	Same as XT
<b>VU</b>	Ramp volume up	Starts volume ramping up
<b>VD</b>	Ramp volume down	Starts volume ramping down
<b>VL</b>	Ramps volume to level (0 – 63)	Sets volume to specific level
<b>VX</b>	Volume Mute off	Restores audio volume to previous level
<b>VV</b>	Stop volume ramp	Stops volume ramping
<b>VT</b>	Toggle Volume Mute	Alternates audio mute on and off
<b>VM</b>	Volume Mute on <i>Example: '&gt;VM'</i>	Turns off audio outputs <i>Mutes audio outputs</i>

A carriage return is required at the end of each command and is assumed in all examples. The '=' sign for parameters may be omitted if desired, though it is helpful for clarity in checking programming.

### **Working with A/V Detectors and Status**

The 232-STSi has two active A/V sensors, the audio sensor detects if the station is broadcasting in stereo or mono, and the video sensor looks for presence of video. If you desire, your control system can respond whenever the status of the audio or video detectors change. For example, you can change the text of a button to MONO or STEREO by tracking the Audio Status Response (V), shown on page 13. In the same way, you can light up a NO VIDEO button, when the Channel/Source Response (T) indicates a video loss.

If you use AV detector status, it's important to understand how the functions will operate in the real world. When you change from a stereo channel to a mono broadcast, the V string will first show the audio status as stereo. When the audio detector locks in, the status will be sent again, indicating mono audio. This is similar to the stereo/mono indicator and "blue screen" functions on your TV, there may be a little delay, and the function may switch back and forth a couple times for marginal stations. So expect that the detectors may send the string a few times as well.

As most applications aren't tracking the A/V sensors, the tuner is normally set not to send a response string whenever the detectors sense a change. You can turn on one or both functions using the Q3 command on page 9.

## RS-232 Control

### Character Generator Commands

The optional character generator supports an on-screen display that is 32 columns (characters) across by 13 rows (lines) down. An imaginary cursor represents the current screen write position. Writing text automatically increments the cursor to the next character space. The character text is always white.

<b>TM=&lt;label mode&gt;</b>	Sets on-screen channel label mode.  0=None 1=Alpha only 2=Numeric only 3=Both alpha and numeric labels  Channel labels are displayed overlaying the video in the top-left corner of the screen for about 10 seconds after each channel change.
<i>Example: '&gt;TM=2'</i>	<i>Sets channel mode to display channel number only.</i>
<b>TN=&lt;channel&gt;,&lt;alpha label&gt;</b>	Sets the alpha label for the specified channel. Alpha labels may be up to 8 characters and are displayed on screen when a channel changes, if alpha labels are enabled by the 'TM' command.
<i>Example: '&gt;TN=8,ABC'</i>	Sets the alpha label for channel 8 to be 'ABC'.
<b>TN=0,0</b>	Clears (blanks) all stored alpha labels
<b>TC</b>	Displays the current channel label on screen for about 10 seconds
<b>DG=&lt;row&gt;,&lt;column&gt;</b>	Moves the cursor to the specified row and column position. If row is 0, then row will not be changed, and if column is 0, then column will not be changed.
<b>E7=&lt;column&gt;</b>	Moves cursor to specified column.
<b>E8=&lt;row&gt;</b>	Moves cursor to specified row.
<b>EA</b>	Clear on screen display. Also, moves cursor to column 1 and row 1.
<b>EB</b>	Moves cursor down to the first column of the next row (like a carriage return plus line feed).
<b>DC</b>	Clear on screen display from the cursor to the end of the screen. Cursor position does not change.
<b>DB</b>	Clear on screen display from the cursor to the end of the current line. Cursor position does not change.
<b>E9=&lt;num spaces&gt;</b>	Clears the specified number of spaces. Cursor position does not change
<b>DM</b>	Clears on-screen display. Also, moves cursor to column 1 and row 1, unblanks screen if it was blanked, and cancels an active 'KC' or 'KT' keypad command
<b>DN&lt;text&gt;</b>	Clears on screen display, then writes the specified text to the display starting at column 1 and row 1.
<b>DW&lt;text&gt;</b>	Writes the specified text to the display starting at current cursor position.
<b>DQ=&lt;time&gt;</b>	Sets screen timeout to specified time in seconds. If time is 0 or 255, any text on the screen will persist indefinitely, or until cleared.

## RS-232 Control

### Keypad Channel Command

If you're using an external control system, this command will emulate the pressing of numeric keypad buttons for channel selection, which means you won't need to use extra elements for capturing channel commands in your programming. The **KC** command will access any channel, **KT** will only access a channel stored in the Tune Ring.

<b>KC=0</b>	Emulates '0' key, accesses any channel.
<b>KC=1</b>	Emulates '1' key, accesses any channel.
<b>KC=9</b>	Emulates '9' key, accesses any channel.
<b>KC</b>	Emulate 'Enter' key, accesses any channel.
<b>KT=9</b>	Emulates '9' key, accesses channel if it exists in current Tune Ring.
<b>KT</b>	Emulate 'Enter' key, accesses channel if it exists in current Tune Ring.
<b>KD</b>	Clears or cancels any KC or KT channel entry

After 3 seconds, with no other key, the selected channel will be tuned to. Optionally, you can have an Enter key send the command **KC** or **KT** to select the channel immediately. Using the **KD** command can cancel a channel entry before the time delay or Enter executes the channel change.

### IC-RC Remote Emulation

You can also emulate IR commands sent from the CR IC-RC Wireless Remote. If you are using the numeric keys to select a channel, the user or program will need to follow the numeric command with an Enter.

<b>KK=&lt;key&gt;</b>	Emulates IC-RC remote key codes  0=Release Key 9=Power (toggling) 10=0 (numeric keypad) 11=1 12=2 13=3 14=4 15=5 16=6 17=7 18=8 19=9 21=Enter  22=Channel up or + 23=Channel down or - 24=Volume up or + (use Release Key (0) to stop volume ramp) 25=Volume down or - (use Release Key (0) to stop volume ramp) 26=Volume mute 31= Input (toggling)  104=Top Menu (TV Standard) 106=Cursor right (Add Channel) 107=Cursor left (Delete Channel) 108=Cursor up (Search Forward) 109=Cursor down (Search Down) 115=CC
-----------------------	--

## RS-232 Control

### Preset Commands and Replies

<b>\$R</b>	Request Presets	Asks for reply with list of presets stored in memory <b>Example:</b> '>\$R' asks for list from Unit 1 <b>Reply:</b> '<1\$TR2-31,35,52,126'
<b>\$G=xxx</b>	Preset Information	Returns preset number, freq, standard, label (1-8 characters) Number of characters follows same structure as T status response <b>Example:</b> '>\$G31' asks for preset 31 information <b>Reply:</b> '<1\$TG031,271.25,02,BBC'
<b>\$N=xxx</b>	Request Label	Asks for reply with channel text assigned to specific channel <b>Example:</b> '>\$N31' asks for label assigned to channel 31 <b>Reply:</b> '<1\$TN031,BBC'

### Terminal Communication Commands

<b>EF</b>	Echo Off	Characters received will not be re-transmitted (power up default).
<b>EN</b>	Echo On	Characters received will be re-transmitted. <b>Example:</b> '>EN' Characters received will be re-transmitted.
<b>ID</b>	Product ID	Returns the product model number and software version.
<b>Z!</b>	Zap	Reconfigures unit for all factory default settings.

### RS-232 Command Hints and Tips

Leading zeros may be included or omitted from command parameters.

**Example:** '>TC=009'      Selects channel 9 as A/V output, same as '>TC=9'.

Multiple commands may be concatenated as single strings up to 120 ASCII characters long.

**Example:** '>XXTC=9'      Selects Mute A/V off, channel 9.

**Example:** '>S0=0S4=0'      Selects CATV mode, no front panel lockout.

Mute A/V Off command is not required in any command; however it may be useful to send Mute A/V Off in case Mute A/V had been set On from the front panel.

Sending all 3 status request commands to the 232-STSi back-to-back for a full status update is allowed.

**Example:** '>STSVSS'      Returns all 3 response strings back-to-back.

The carriage return line feed at the end of each 232-STSi response allows for easy monitoring of responses with an ASCII terminal program. You may use ASCII CR, Hex \$0D, or keyboard 'Enter' in programming.

You don't have to use the '=' character between the command and parameter – the string works either way.

## Response Strings

Typical: [Attention] [Unit#] [data ...data] [cr] [lf]

232-STSi status response strings contain ASCII characters similar to those used for the same functions in command strings. An ASCII 'carriage return' and 'line feed' follow each response string.

Functions shown as N/A are not applicable; characters will appear in status strings as lower-case x.

### Channel/Source Status Response String (T):

Start	Unit	CMD	Power	Channel 1	Video Mute	N/A	Video Present	Reference
	1-9		U=On M=Off	Current Channel 3 digits	U=Unmuted M=Mute	2 digits	N=No Video Y=Video	Frequency TV Standard xxx.xx,xx
<	<b>1</b>	<b>T</b>	<b>U</b>	<b>008</b>	<b>U</b>	<b>xx</b>	<b>Y</b>	<b>271.25,02</b>

### Audio Status Response String (V):

Start	Unit	CM D	Power	Volume	Volume Mute	Stereo
	1-9		U=On M=Off	0-63 2 digits	U=Unmuted M=Mute	S=Stereo M=Mono
<	<b>1</b>	<b>V</b>	<b>U</b>	<b>63</b>	<b>U</b>	<b>S</b>

### Front Panel Mode Status Response String (S):

Start	Unit	CMD	Audio Mode	Channel Plan	Lockout	Bass	Treble	TV Standard
	1-9		0-3	Not Applicable	0-9	0-9 2 digits	0-8	1-8 2 digits
<	<b>1</b>	<b>S</b>	<b>1</b>	<b>0</b>	<b>1</b>	<b>08</b>	<b>4</b>	<b>01</b>

### Q Mode Response String (Q):

Start	Unit	CMD	Q0	Q1	Q2	Q3	Q4	N/A
	1-9		0-2	1-8	0=AV Muted 2=Video Muted	0-3	0-3	5 digits
<	<b>1</b>	<b>Q</b>	<b>2</b>	<b>1</b>	<b>0</b>	<b>0</b>	<b>x</b>	<b>xxxxx</b>



# RS-232 Cable Connections

## Single Tuner

### Control Wiring – Single Unit

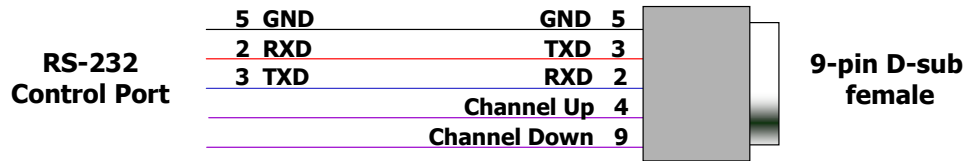

RS-232 wiring for control or programming should only use pins 2, 3, 5. Cables with all pins wired can lock out front-panel programming and data communication (Pins 4 and 9 are inputs).

## Multiple Tuners

Up to nine tuners can be daisy-chained from one RS-232 control port. Remember that you will need to use the Unit# address in your programming when you control more than one tuner from the same control port.

Set the first unit in the RS-232 chain to the highest Unit#, then wire in sequence to the last tuner in the chain. The reason for this is that CR tuners use an intelligent data bus - the highest number tuner receives all commands, and then passes on commands addressed to tuners with lower unit numbers. The next tuner in the chain does the same, and so on until the last unit.

### RS-232 Wiring – Two Units

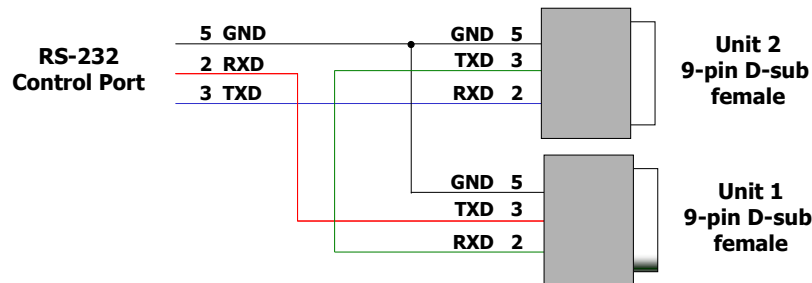

### RS-232 Wiring – Three Units

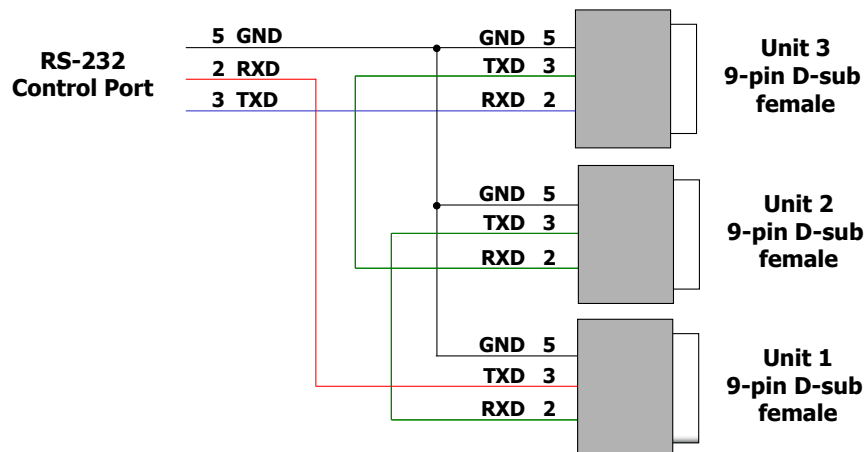

## Rack Mounting

Two options are available for rack-mounting tuners.

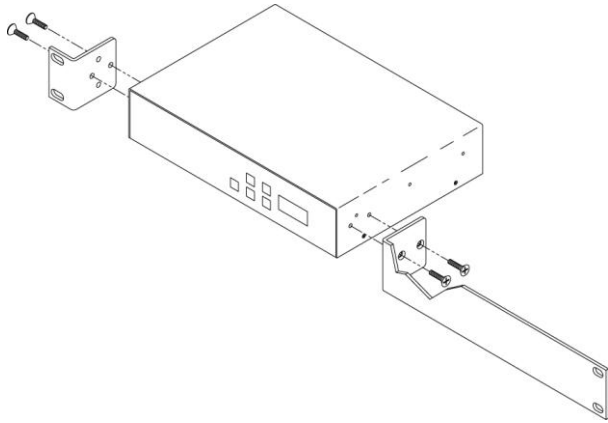

*RK1 Rack Mount*

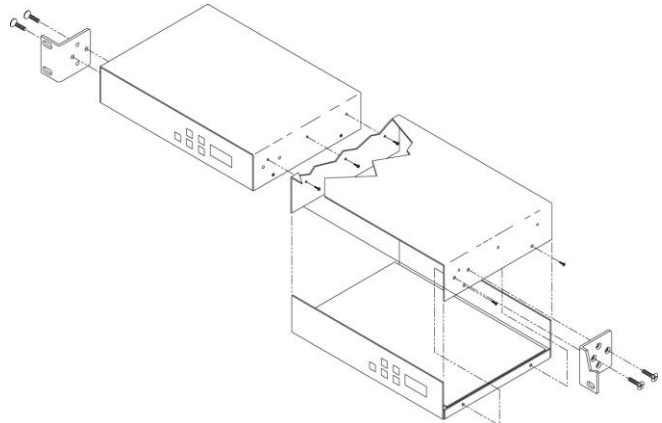

*RK2 Rack Mount*

### RK1 Single Unit Rack Mount

Size Long Bracket:	9.5" [206mm] wide x 1.75" [38mm] height (1RU) x 1.75" [38mm] deep
Size Short Bracket:	1.0" [22mm] wide x 1.75" [38mm] height (1RU) x 1.75" [38mm] deep
Weight:	3.25 oz [0.148kg]
Enclosure:	All aluminum with durable black powder coat paint
Hardware:	Qty 4 CS, Phillip, Flathead, 82deg, Black, 8-32 x .25"

Attach the long and short rack ears to the side and towards the front of the unit with the four (4) supplied 8-32 by 1/4" (black) countersunk screws.

### RK2 Side-by-Side Rack Kit

1. Remove top cover of the first unit by removing the ten (10) black screws.
2. Attach cover of first unit to the side of the second with three (3) supplied 4-40 by 1/4" (silver colored) panhead screws and split lock washers. Note that only one side of the second unit has the (3) built in nuts to accept the screws above.
3. Reinstall the bottom/chassis of the first unit underneath its cover and attach with just eight (8) of the screws removed in step 1.
4. Attach short rack ears to the side and towards the front of each unit with the four (4) supplied 8-32 by 1/4" (black) countersunk screws.

## Safety Instructions

### Read before operating equipment.

1. **Cleaning** - Unplug this product from the wall outlet before cleaning. Do not use liquid cleaners or aerosol cleaners. Use a damp cloth for cleaning.
2. **Power Sources** - Use supplied or equivalent UL/CSA approved low voltage DC plug-in transformer.
3. **Outdoor Antenna Grounding** - If you connect an outside antenna or cable system to the product, be sure the antenna or cable system is grounded so as to provide some protection against voltage surges and built-up static charges. Section 810 of the National Electrical Code, ANSI/NFPA No. 70, provides information with respect to proper grounding of the mast and supporting structure, grounding of the lead-in wire to an antenna discharge unit, size of grounding conductors, location of antenna discharge unit, connection to grounding electrodes, and requirements for the grounding electrode.
4. **Lightning** - Avoid installation or reconfiguration of wiring during lightning activity.
5. **Power Lines** - Do not locate an outside antenna system near overhead power lines or other electric light or power circuits or where it can fall into such power lines or circuits. When installing an outside antenna system, refrain from touching such power lines or circuits, as contact with them might be fatal.
6. **Overloading** - Do not overload wall outlets and extension cords as this can result in a risk of fire or electric shock.
7. **Object and Liquid Entry** - Never push objects of any kind into this product through openings as they may touch dangerous voltage points or short out parts, resulting in a fire or electric shock. Never spill liquid of any kind on the product.
8. **Servicing** - Do not attempt to service this product yourself as opening or removing covers may expose you to dangerous voltage or other hazards. Refer all servicing to qualified service personnel.
9. **Damage Requiring Service** - Unplug this product from the wall outlet and refer servicing to qualified service personnel under the following conditions:
  - When the power supply cord or plug is damaged.
  - If liquid spills or objects fall into the product.
  - If the product is exposed to rain or water.
  - If the product does not operate normally by following the operating instructions. Adjust only those controls that are covered by the operating instructions. An improper adjustment of other controls may result in damage and will often require extensive work by a qualified technician to restore the product to its normal operation.
  - If the video product is dropped or the cabinet is damaged.
  - When the video product exhibits a distinct change in performance, this indicates a need for service.

**\* Note to CATV system installer:** This reminder is provided to call CATV system installer's attention to Article 820-40 of the National Electrical Code (Section 54 of Canadian Electrical Code, Part I), that provides guidelines for proper grounding and, in particular, specifies that the cable ground shall be connected to the grounding system of the building as close to the point of cable entry as possible.

## **Limited Warranty and Disclaimer**

Contemporary Research Corporation (CR) warrants this product to be free from defects in material and workmanship under normal use for a period of two years from the date of purchase from CR. Should such a defect occur CR will repair or replace, at their option, the defective product at no cost for parts or labor.

This warranty extends to product purchased directly from CR or an Authorized CR Dealer. Consumers should inquire from selling dealer as to the nature and extent of the dealer's warranty, if any.

All warranty claims must be shipped pre-paid to the factory. Call or fax to obtain a Return Material Authorization (RMA) number.

CR is not liable for any damages caused by any of its products or for the failure of any products to perform, including any lost profits, lost savings, incidental damages, or consequential damages. CR is not responsible for any claim made by a third party or made for you by a third party. This limitation of liability applies whether damages are sought, or a claim is made, under this warranty or as a tort claim (including negligence and strict product liability), a contract claim, or any other claim. This limitation of liability cannot be waived or amended by any person. This limitation of liability will be effective even if CR or an authorized representative of CR has been advised of the possibility of any such damages.

Some states do not allow a limitation of how long an implied warranty lasts. Some states do not allow the limitation or exclusion of incidental or consequential damages for consumer products. In such states, the limitation or exclusion of the Limited Warranty may not apply to you. This Limited Warranty gives you specific legal rights. You may also have other rights that may vary from state to state. You are advised to consult applicable state laws for a full determination of your rights.

Except as expressly set forth in this Limited Warranty, CR makes no other warranties, expressed or implied, including any implied warranties of merchantability or fitness for a particular purpose. CR expressly disclaims all warranties not stated in this Limited Warranty. Any implied warranties that may be imposed by law are limited to the terms of this Limited Warranty.